



VANGUARD

Vanguard Sailboats
300 Highpoint Avenue
Portsmouth, RI 02871

**For the dealer
nearest you call**
800.966.SAIL

Bigging Manual



Sunfish

Getting Started

Unpacking and preparation

Unpack the major parts listed below and lay them out on a soft piece of ground free of sharp objects. To avoid damaging contents, do not cut into packaging.

1. Hull
2. Mast kit which includes:
 - Mast
 - Two booms (linked together, one with "gold" gooseneck)

3. Parts kit which includes:
 - Sail rings
 - 2 Brummel hooks
 - Bailer
 - S hook
 - Mainsheet block
 - Mainsheet snap hook

4. Line bag which includes:
 - Mainsheet
 - Daggerboard retainer
 - Daggerboard safety line
 - Outhauls (2)
 - Halyard

5. Sail in bag
6. Daggerboard
 - Rudder assembly
 - Tiller assembly

Knots

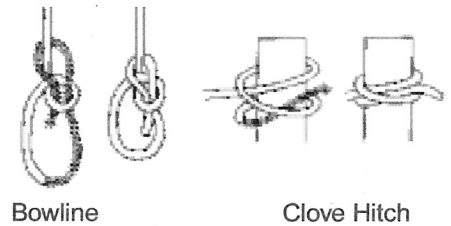
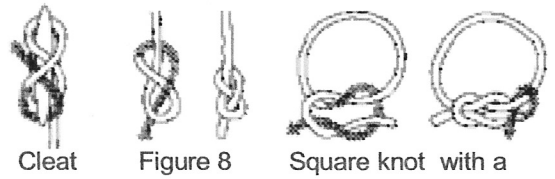

Tools

To rig your Sunfish the first time, you will need the following tools:

- 2 adjustable wrenches
- Pliers
- Knife
- Electrical tape



Installing the bailer

The bailer lets water out of the cockpit while you are sailing. Locate the bailer plug and cap and fit the cap into the hole in the plug so the plug stopper faces up. Fit the O ring over the bailer housing, then thread the two pieces together through the hole in the hull with the housing underneath the boat and the cap on top. Tighten hand tight and make sure the housing ends up with the flat facing aft. When open, the stopper should lie on the cockpit sole pointing toward the bow.

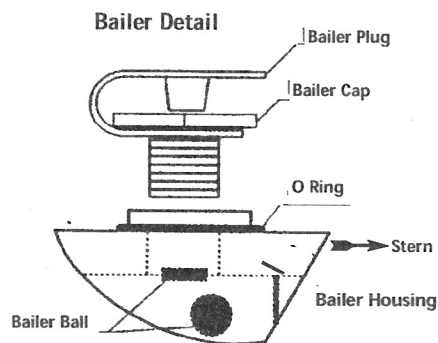

Attaching the sail to the booms

Spread out the sail, making sure there are no sharp objects nearby that could damage it. Open the booms and lay them along the two edges of the sail that have grommets. The Sunfish logo should face the upper boom, which is the one with no blocks attached. Locate the S hook from the line bag and hook it into the tack grommet (the larger hole in the corner of the sail closest to the class association patch). Hook the other end into one of the eyebolts holding the booms together and crimp the S-hook closed with pliers.

Lace one of the outhaul lines through the grommet in the sail close to the outboard end of the top boom, and then feed each end through the hole in the boom end cap. Tie a figure eight in each end. Repeat this step for the lower boom with the other outhaul line. The outhauls should be fairly tight. Attach the sail to the booms with the sail rings, just as you would hang a shower curtain.

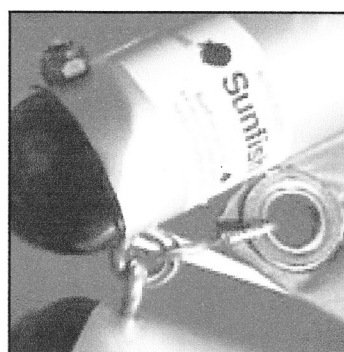

Grommet and S Hook

Daggerboard assembly

Remove the daggerboard from its wrapping and attach one end of the safety line to the daggerboard. The other end will attach to the mainsheet deckstrap once the boat is launched. Tie each of the two brummel hooks onto the ends of the shockcord. Find the midpoint of the shockcord and feed it (as a loop) through the hole in the daggerboard. Pass both ends through that loop, keeping the lengths fairly even. Set the board aside.

Rigging

Attach the mainsheet swivel block to the boat by removing the clevis ring and pin, placing the block over the deckstrap at the forward end of the cockpit, and replacing the pin and ring. Tie one end of the mainsheet to the mainsheet hook. Pass the other end forward through the two blocks on the lower boom and down through the mainsheet block, then tie a figure eight knot.

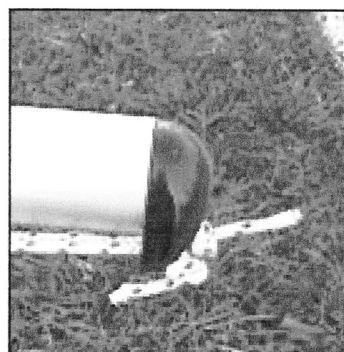

Outhaul Line

Rudder

Attach the rudder to the tiller using the supplied bolt and washers. The washers should sit between the tiller and the rudder, one on each side. Lock the rudder up and attach it to the boat by passing the tiller under the traveler and lining up the rudder pin with the pintles. The bottom groove should fit into the bottom pintle, and when you push down on the spring loaded pin, the top groove will slide into the top pintle. Release the spring and lock the rudder in place, making sure the rudder is securely connected to the boat at both top and bottom.

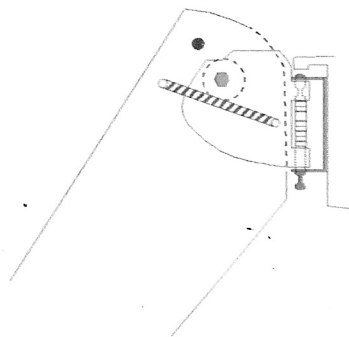

Rudder & Tiller
Assembled and Mounted

Stepping the mast

Make sure there are no overhead wires in the area and that the mast step hole and mast butt are perfectly clean; any sand, dirt etc. in the mast step will grind into the gelcoat and eventually damage the boat. Lie the booms and sail on the deck of the boat with the bronze gooseneck over the mast step hole. Feed about half the halyard through the hole in the top of the mast and set the mast heel down through the gooseneck into the mast tube. Put three wraps of electrical tape around the upper booms between the ninth and tenth sail rings, counting from the tack (lower corner) of the sail. (The tape will keep the halyard from slipping up to the next sail ring.) Tie the aft end of the halyard to the upper boom with a clove hitch just below the tape.

Raising the sail

Make sure the bow of the boat is pointing into the wind. Clip the mainsheet to the bridle. Raise the sail by pulling on the halyard. You will need to help the boom off the deck by lifting at the gooseneck. Pull the halyard until the upper boom is right against the mast, and pull the tail of the halyard through the main halyard bullseye fairlead. Secure the halyard to the main halyard cleat.

Knots

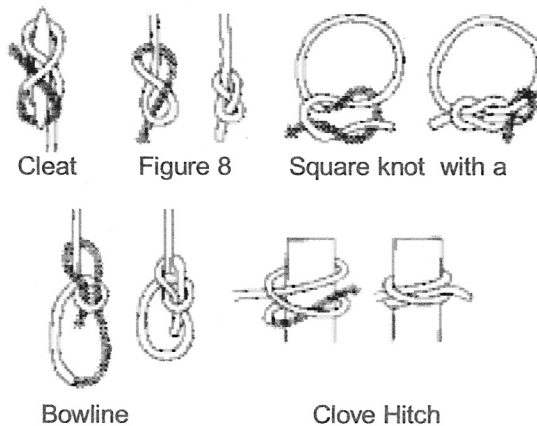

Use the clove hitch to tie the halyard to the upper boom. When the sail is up, secure the halyard to the cleat as shown.

Launching

Check that the drainplug is in place and tight. The automatic bailer should be closed. With the boat in a few feet of water, slide the daggerboard into the daggerboard trunk. (You will have to turn the boat sideways to the wind to keep the boom clear.) Drop it down as much as depth permits. Attach the retainer line to the mainsheet deck strap. (This prevents the daggerboard from falling out in the event of a capsize.) Pass one end of the shockcord through the metal strap on the bow, and hook the two brummel hooks to each other. Push the rudder down if the water is deep enough.

Unrigging

When approaching shallow water, pull up the daggerboard as much as possible without obstructing the boom, and kick up the rudder. After you hop out of the boat, unclip the mainsheet from the traveler. Remove the daggerboard and place it in the boat. Once the boat is on land, drop the main halyard. If the boat is traveling, remove the mast and place it in line with the booms. Pull the sail out taught and roll it up against the spars, securing it with the halyard. If the boat is staying put, leave the mast standing, roll the sail up against the booms, and secure it with the mainsheet.

Sail care

All gear should be rinsed, if sailing in salt water, the sail should be allowed to dry before it is rolled up. Roll the sail up to the booms and not around them. If your sail has a window make sure the window is not creased when you fold or roll the sail.

**NOW YOU ARE
READY TO SAIL**

**FOR YOUR OWN SAFETY, MAKE SURE
YOU ARE WEARING APPROPRIATE
CLOTHING FOR THE CONDITIONS,
AND PLEASE OBTAIN PROPER TRAINING
BEFORE SAILING. HAVE FUN AND
DON'T FORGET YOUR LIFE JACKET!**

